



APPLICATIONS: Converts 3832C, Detent-Out, Self-Close, and Heavy-Duty Self-Close slides for face frame mounting. Front and rear brackets easily snap on the existing slide. No tools needed. **This product covered by US (5,904,412) and various foreign patents issued and/or pending.**

FACE FRAME CONVERSION KIT

Part Number 4180-0322-XE

**For Use With Slide Models
3832CDO, 3832CHDSC, 3832CSC, 3832C
3834CSC, 3834C**

Installation Instructions

See Model 3832C, 3832CSC, 3832CHDSC, or 3832CDO data sheet for additional slide details.

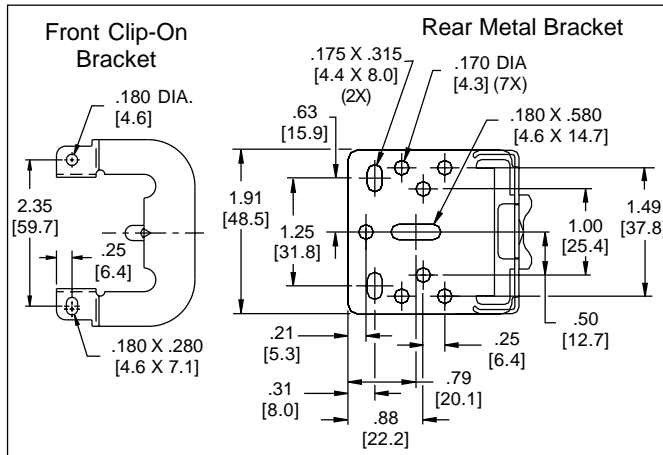

Attach Brackets to Slide Member

First, separate slide members by actuating the disconnect lever. Brackets are attached to cabinet (large) member.

Attach Front Bracket

1. Position bracket on slide so tab engages second hole on slide. Bracket flanges will face inboard. See Figure 1.
2. Rotate bracket until it snaps in place, flush with front.

Attach Rear Bracket

1. Push rear bracket onto the slide. Ensure locking lug on plastic slider engages the mating hole in the slide member **and** the bumper on the slide seats into the plastic slider on the bracket. See Figure 1.

Mount Slide to Cabinet

1. Secure a 3/4" x 2" vertical mounting strip to the rear wall or cabinet back for each slide.
2. Position the front bracket on the face frame opening and move it forward until the self-register stop hits the inside of the face frame opening. Install screw in the slotted mounting hole. Do not tighten screw completely at this time.
3. Extend the rear bracket until it contacts the rear vertical mounting strip. Check that both cabinet members are vertically and horizontally parallel. Mount the rear bracket using the two vertical slots. Make any necessary adjustment. See Figure 2.
4. Secure the rear bracket with a screw in round hole. Secure the front bracket with a screw in the round hole of the bracket. Tighten the original screw. See Figure 2.

Mount Slide to Drawer

1. Install drawer member through vertical slots.
2. Insert drawer member making sure ball bearing retainers are fully forward. Close drawer completely.
3. Adjust vertical position and install 2 more screws in round holes after free movement is achieved. See Figure 3.

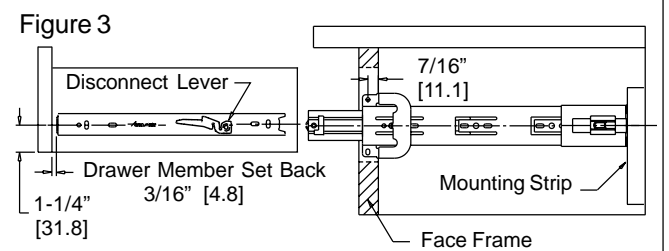
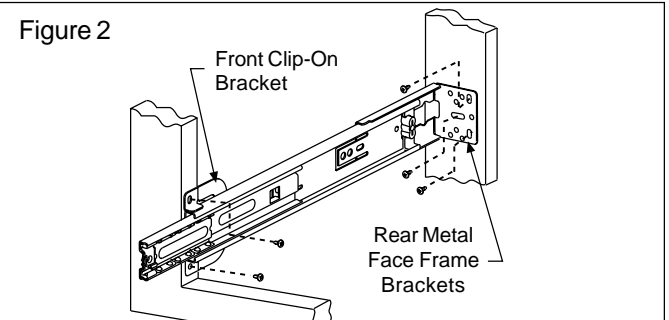
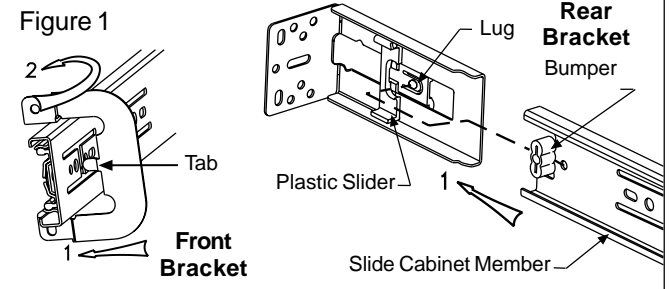

Ordering / Packaging Information

Order brackets in a **kit** or in **bulk**. Mounting screws are **not** included. Brackets are available in zinc finish only.

For face frame **kit**, order part number 4180-0322-XE. Each kit contains 2 front and 2 rear brackets, and installation sheet. Order one kit per pair of slides ordered.

For **bulk**, order 2 front (part number 4010-0516-CE) and 2 rear (part number 4080-0508-CE) brackets per pair of slides.

Specifications

Front and rear face frame brackets: Cold rolled steel

Note: Specifications, materials, prices, terms, and delivery are subject to change without notice.



ACCURIDE INTERNATIONAL INC.

12311 Shoemaker Avenue
Santa Fe Springs, CA 90670
TEL (562) 903-0200
FAX (562) 903-0208
www accuride.com

Manufacturing, Engineering, and Sales
United States • Germany • Japan • Mexico • United Kingdom